



## 1 Introduction

This document describes how the electronics are packaged and how they are placed in relation to the instrument dewar. There are two levels of packaging. The circuit boards and other components are mounted in individual crates, and the crates are rack-mounted in an overall enclosure.

## 2 Cabinet Placement

Our initial idea was that a single tall 19" rackmount cabinet, housing all the electronics and incorporating cooling, would be placed right behind the instrument (i.e. at the opposite end from the input window), thereby keeping the analog electronics as close as possible to the  $1024^2$  detector. However it became clear during discussions at the PDR that we would have to abandon that idea, because it would not fit the space on the left Nasmyth platform when NIRSPEC gets its input beam from the AO bench.

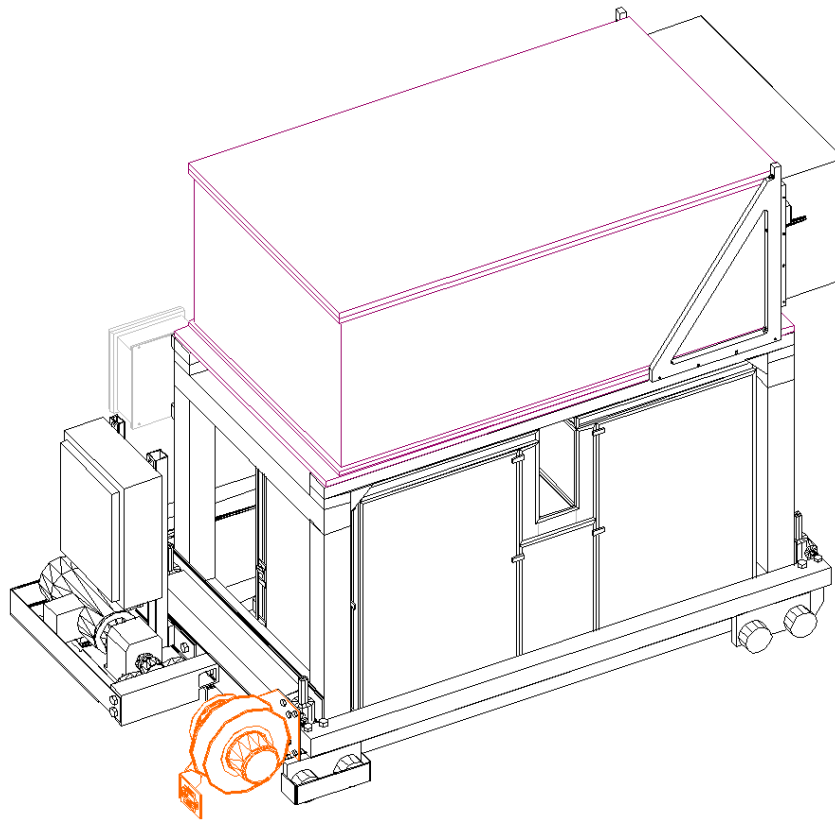

1: Electronics cabinets underneath instrument

Instead we put the electronics into the space underneath the instrument. This has lots of advantages in that it keeps the instrument footprint as small as possible, and makes it completely self-contained.

This did involve some difficulty working around things like the vacuum feedthroughs and CCR heads on the bottom of the dewar. In particular the LN<sub>2</sub> can is situated right in the middle of the instrument, so the fill and exhaust ports come out in the middle of the bottom surface. The hermetic feedthrough connectors are also on the bottom surface. The placement of the CCR heads is especially critical, since they are so large in the vertical dimension that they would greatly impact the height of the electronics cabinets. However by pushing the electronics cabinets to the right as far as possible and the CCR heads to the left, we were able to fit them together without interference.

To deal with the problem of the LN<sub>2</sub> ports, we pushed the two cabinets a foot apart rather than joining them together side by side. We made a framework of 1" by 1" aluminum angle to connect the cabinets, and also give us a place to put several components such as the cryogenic temperature controllers that aren't supplied in 19" rack format.

The two cabinets are standard off the shelf units from Schroff, each with 20U of rack mount height. This proved to be just enough space to fit everything inside.

### **3 Units housed in the cabinets**

We had to house the different units according to constraints such as minimizing the length of analog signal cables, and keeping digital and analog units separate. The list below gives the size and location of each unit. When we refer to the left and right cabinets, this is as seen from the front of the rack mount chassis, which is on the right hand side of the instrument. This is the face shown in the view in Figure 1.

- Spectrometer channel analog electronics: a 6U<sup>1</sup> high VME chassis.
  - Slit-viewing camera analog electronics: a 3U chassis.
  - Main transputer crate: a 6U chassis.
  - Spectrometer channel analog power supply
- ! Level shifter boards, to drive the 256<sup>2</sup> and 1024<sup>2</sup> array detectors. The level shifters may go in separate cases outside the main enclosure, or in slim (1 or 2U) cases in the racks.
- ! Motor driver units. These take step and direction signals from the motor controller transputer boards and drive the stepper motors in the internal mechanisms: a 3U chassis will be big enough.

---

<sup>1</sup> Eurocard chassis are specified in terms of "U" units, where 1U = 1.75". So a 6U chassis is approximately 11" high.

- ! Power supplies for the light sources in the calibration unit, plus any required control circuitry for shutters and the light sources: should fit in a 3U or 4U case but this requires some further research.
- ! Electronics to drive the guider CCD camera: not yet known, depends on choice of CCD camera.
- ! Cooling units which will cool the air in the cabinet using the observatory coolant supply. These may be as big as 4U cases or perhaps smaller. We are still working with the vendors.

### **3.1 Analog electronics**

#### **3.1.1 1024<sup>2</sup> array camera**

The analog electronics for the 1024<sup>2</sup> array camera mostly consist of a set of pre-amp/A-D converter boards. Each board will have two complete analog channels, so we will need 16 of these boards for the 32 output channels of the array. The boards will plug into a modified Sun style backplane. Housed alongside them in the backplane will be an offset/decoder board (sometimes referred to as board 17). This board will have power regulators for the analog boards, circuitry to set the offset for the four quadrants of the array, and decoding for the gain and bandwidth select signals coming from the clock generator board. We will bring in the analog signals from the dewar via individual pins to each board, and use bussed lines to pass the decoded gain and bandwidth select lines from the regulator/decoder board to the other boards.

#### **3.1.2 Slit viewing camera**

The slit viewing camera will have a NICMOS III 256<sup>2</sup> array, requiring its own analog boards. This array will be nearer to the front (window) end of the instrument, quite a distance from the 1024<sup>2</sup> array. In order to have the two cameras completely isolated from each other we will put the analog boards for the slit viewer camera array in a separate 3U high chassis, with a 4 or 5 slot backplane and the boards placed horizontally. This layout would allow us to put them in the right hand side cabinet, closer to the 256<sup>2</sup> array near the front of the instrument, obviating the need to put the pre-amps in a separate enclosure.

#### **3.1.3 Bias supply**

The bias supply circuits will also be implemented as 6U VME format boards, housed in the same crates as the analog (pre-amp & A-D) boards for each camera. Although there will be some switching of bias levels, this will be slow and not concurrent with pixel readout, so this board can safely be placed with the low-noise analog boards, not the digital part of the system.

### **3.2 Transputer boards**

The transputer boards in this system will be laid out in 6U VME format and plugged into a VME backplane in a Eurocard cage. The boards will draw only power from the VME backplane, and the transputer links from board to board will be passed via the uncommitted wirewrap pins of the J2 VME connector. There are two types of board, the combined clock/motor controller boards and the data acquisition boards. For details of the board designs, see NEDN02.

There will be five of the acquisition boards and four or five clock generator/motor controller boards. In addition there will be a VME style motherboard carrying TRAM daughterboard modules: these provide the fiber-optic data link to the host and the RS232 interface for auxiliary control and monitoring of temperatures. Given this number of boards, there should be plenty of room for the front panel widths required in a standard 19" case with a 20 or 21 slot backplane.

### **3.3 Power supplies**

We will probably use packaged power supplies from Acopian. This vendor offers a service where they pre-package the required power supplies in a 19" rackmount chassis with connectors and readouts. There will be two of these enclosures, one holding the supplies for the analog section and one for the digital (transputer board) power supplies. These will be segregated from each other like all the other analog and digital sections. Supply to the other crates and to the external components driving the slit viewing camera will be via screened cables.

### **3.4 Level shifters**

The level shifter boards will be switching fast during pixel readout, so they must obviously be kept away from the low-noise analog subsystems. However they may also be susceptible to picking up transients from the digital boards and feeding them through to the array, so we should also keep them away from the transputer boards. Therefore we will probably house the level shifters in their own shielded enclosure on the outer wall of the dewar, as in the Gemini system, or in a separate, low profile rackmount case.

### **3.5 Motor drive modules**

The motor controller boards will provide step and direction signals, and commercial driver modules will convert these to the high current pulses required for the stepper motors. The driver modules are individually quite compact. We will house them in a separate 19" crate, heavily shielded to keep them from introducing any noise into the rest of the system. The cables carrying the current to the different motors inside the dewar will likewise be shielded to prevent radiation of noise. This is particularly important in the case of the motor for the image rotator, since this is the only motor which will be operating concurrently with operation of the detector arrays. The driver for the image rotator will be a linear type in order to reduce noise, making it larger and heavier than the others. It should be possible to package all the drivers in a single 19" crate. Since the total weight will be quite

considerable, I suggest we put this crate on slides and provide access through the top panel, so it is easy to maintain.

### **3.6 Calibration unit**

The calibration unit has to turn on and off arc lamps and tungsten bulbs, and control shutter/pinhole mechanisms. We will have a number of different small units, so like the motor drivers we will put them together in a single chassis and make it easy to get at each unit from the top for maintenance.

### **3.7 Autoguider electronics**

The dimensions of the autoguider electronics are not yet known, but are likely to be at least a 3U size. One possible model is a little smaller than a 19" rackmount case, but we could put it in a 19" chassis for convenience of mounting.

### **3.8 Cooling units**

We have been investigating various cooling units, but the most attractive choice may be the Knurr system, since their water/air heat exchangers are only 2U high.

## **4 Overall enclosure**

The enclosure needed to house all our rackmount equipment needs to be completely enclosed, with front and rear doors for access to the equipment. As noted in section 1, we had thought of a single enclosure, standing behind the instrument, but now need to fit everything underneath the instrument. We should be able to fit all the components into two small (~ 3 feet tall) cabinets. We have checked with sales engineers from several manufacturers that it is not a complicated business to use two off the shelf cabinets joined together, making a single volume to be cooled. This means that both cabling and the circulation of cooled air will be easier.

### **4.1 Placement and available space**

The cabinets will probably be 2 feet square and 3 feet high, though we might choose to have them a little wider to help cool air circulation (see section 4.2). They must be situated so the analog electronics are as close as possible to the rear of the NIRSPEC dewar, to minimize the distance between the pre-amps and the  $1024^2$  detector array, which will be at that end of the dewar. (If we decide to fold the optical design to reduce the length of the dewar, the detector will still be at that end, but may be more off to one corner.) In any case, the major problem may be the location of the CCR heads on the bottom surface of the dewar. We have a conflict because we want to get the second stage of the two-stage CCR head fairly close to the detector head inside the dewar, although this isn't as vital as keeping the signal cable lengths short. This is definitely an item that warrants further study, and folds into considerations of cryogenic, optical and mechanical design too.

Another unresolved problem at this stage is the size of the support structure. If the optical design remains unfolded, then a support frame with the same footprint as the dewar (legs under each corner of the dewar) will have adequate room underneath. If we shrink the dewar we might have to have the support structure longer than the dewar itself just to keep the space free for the electronics. We have to keep the front and rear access to the electronics racks clear of obstruction, otherwise we have failed to keep to one of our design goals on accessibility.

A recent new piece of information is that the tracks on which the instrument will roll for access to the two Nasmyth platforms of Keck II will be quite a bit wider than the proposed width of NIRSPEC. In other words there might be an opportunity to increase the footprint slightly if we are really having trouble getting the electronics to fit. We are also trying to arrange the optomechanical layout inside the dewar so the every optical component is as close as possible to the optical support plate. This effort will have the effect of raising the bottom surface of the dewar, since the optical path remains fixed at 1.5 m above the Nasmyth deck.

Since there is so much still to be settled about the optical and mechanical layout of the instrument, We should not expend much more effort on trying to place the electronics for the moment, but keep electronics placement in mind when beginning design of other sections of the instrument such as the support structure.

## **4.2 Cooling and insulation**

### **4.2.1 Heat exchangers**

To prevent the equipment dumping heat into the telescope dome we need to insulate it so we don't dissipate more than 50W. However the equipment will be dissipating around 750W inside the cabinets, so we need to do something to prevent heat building up inside. There is an observatory supply of water/glycol cooling liquid which can give us up to 1500 W of cooling. What we will have to do is insulate the outside panels and front and rear doors of the cabinets, and use one or more water/air heat exchangers. These are available from a number of vendors, with the Knurr or Lytron units looking most attractive. We will need a separate unit for each of the two cabinets, so that we don't have a problem with local hot spots. Some ducting of the air to and from the cooling units might also help. Woon and I had discussed this idea, and the Knurr sales engineer suggested the same thing. The Knurr units draw air in at one side and expel cooled air from the other. He suggested we make a simple duct from the input side of the coolers to draw hot air from the top of the cabinets.

In order to guard against overheating in the event of coolant failure, we must make sure the inside of the cabinets is properly instrumented. The Knurr cooler units have some useful features. They actively control coolant flow to regulate temperature, so they have air temperature sensors. They have a two-stage alarm setup. If the temperature goes over the set point a light comes on on the front panel, and if it goes much higher a relay is tripped. We could use this relay output both for an audible alarm and for computer sensing and notification of the operators.

#### 4.2.2 Insulation

If we have a pair of cabinets, each 3 feet high by 2 feet square (0.9 by 0.6 m) , we will have a total area of approximately 4.7 square meters. Typical values for the inside and outside temperatures would be 20°C and 0°C. From manufacturers' literature, the typical heat transmission of a metal cabinet without any added insulation is 5 W/m<sup>2</sup>K. Thus our total heat dissipation would be 4.7 X 5 X 20 = 470W. That is well over our 50W limit. To achieve the 50W limit we need to get down to less than 0.53 W/m<sup>2</sup>K. I will talk to the sales engineers about what insulation can be supplied, but will also research a little myself into available products.

#### 4.2.3 Airflow inside the cabinets

In addition to the cooling of the whole interior of the cabinet, we need to make sure that each individual chassis has adequate airflow to keep its components cool. The air at the summit of Mauna Kea is very thin (about 2/3 sea level density) and usually very dry, reducing the cooling capacity. We will add fans to every individual chassis so that all components have sufficient airflow to take advantage of the cool environment we have provided inside the cooled and insulated cabinet. We must find out how to derate cooling capacities for the effects of altitude.

### 5 Cabling

Some of the cabling will be internal to the overall enclosure, running from chassis to chassis, but most of it will have to pass through the cabinet walls to the dewar lower surface. If possible we should pass all the cables that have to make that transition through the side walls of the cabinets, that is the faces that are simply blank panels, not doors. At the rear of the cabinets we should use a shortened door and have a fixed panel at the bottom for ingress of 110V power and liquid coolant. All cables going through panels should go through bulkhead connectors and use latching or screw on connectors so that there is no danger of accidental disconnection. The liquid connection should be the spill proof quick disconnect type.