

# FLITECAM, a 1-5 micron camera and spectrometer for SOFIA

Ian S. McLean<sup>a</sup>, Erin C. Smith<sup>a</sup>, T. Aliado<sup>a</sup>, G. Brims<sup>a</sup>, E. Kress<sup>a</sup>, K. Magnone<sup>a</sup>, J. Milburn<sup>a</sup>, A. Oldag<sup>a</sup>, T. Silvers<sup>a</sup>, G. Skulason<sup>a</sup>, Eric E. Becklin<sup>b</sup> and Ralph Y. Shuping<sup>b</sup>

<sup>a</sup>Dept. Physics & Astronomy, UCLA, 475 Portola Plaza, Los Angeles, CA 90095-1547

<sup>b</sup>USRA-SOFIA, NASA Ames Research Center, MS 211-3, Moffett Field, CA 94035

## ABSTRACT

FLITECAM is a 1-5 micron infrared camera for NASA's Stratospheric Observatory for Infrared Astronomy (SOFIA). A 1024 x 1024 InSb ALADDIN III detector and large refractive optics provide a field of view of almost 8 arc minutes in diameter with a scale of just under 0.5 arc seconds per pixel. The instrument is cooled by a double liquid helium and liquid nitrogen cryostat. Using a collimated beam of about 26 mm diameter, a low resolution spectroscopic mode is also available using direct-ruled KRS5 gratings and fixed slits of either 1" or 2" width and 60" length to yield resolving powers of  $R \sim 1700$  and 900 respectively. FLITECAM has been partially commissioned at the 3-m Shane telescope of Lick Observatory where the  $f/17$  optics of this telescope provides almost the same plate scale as SOFIA. Astronomical observing requests (scripts) and a real-time data reduction pipeline (DRP) for dithered image patterns have been demonstrated. The performance of the instrument during ground-based trials is illustrated.

**Keywords:** Infrared instrumentation, airborne astronomy, SOFIA

## 1. INTRODUCTION

FLITECAM is one of a suite of nine instruments being developed for SOFIA, the Stratospheric Observatory for Infrared Astronomy<sup>1</sup>, which is a modified Boeing 747-SP airplane with a 2.5-meter  $f/19.6$  bent-Cassegrain telescope operating at altitudes up to 45,000ft and therefore above 99% of the atmosphere's water vapor content. As a result, the transmission of infrared light long-ward of 2.5  $\mu\text{m}$  is significantly improved compared to any ground-based telescope. Designed to perform imaging in selected bands over the wavelength range 1-5.5  $\mu\text{m}$ , FLITECAM is an instrument that bridges the transition region of wavelengths where ground-based observations become severely limited by the thermal background emission of the telescope and sky, and the much longer wavelengths for which SOFIA is primarily designed. With the colder, drier air and colder telescope ( $\sim 240$  K), FLITECAM on SOFIA will be an order of magnitude more sensitive in the 3-5  $\mu\text{m}$  region than at ground-based sites. FLITECAM is designed to provide images over the 8' diameter field of view of SOFIA at a moderate resolution of  $\sim 0.46''/\text{pixel}$  because turbulence is expected to control seeing conditions at wavelengths less than 5  $\mu\text{m}$ . It has been challenging to develop this instrument for several reasons. The large field of view implies large optical components which have had to be mounted carefully and cooled very slowly to minimize thermal shock. Constraints on the cryo-mechanical design were also imposed by stringent FAA safety regulations for operation on board the aircraft. Layout and geometry were further constrained by the desire to co-mount FLITECAM with another instrument, HIPO<sup>2</sup>, in order to provide the capability for simultaneous optical/IR occultation observations. Because FLITECAM is required to test the SOFIA facility, a spectroscopic mode with a resolving power  $R \sim 1000$  and a pupil viewing mode, were also added to the requirements. Several previous papers have described the initial instrument concept for FLITECAM<sup>3,4,5</sup> which has evolved to the final version described in this paper.

FLITECAM has been operated successfully on multiple occasions at the 3-meter Shane telescope at the University of California's Lick Observatory on Mt. Hamilton. First light was obtained in October 2002 and the instrument has accumulated data on eight separate occasions. Photometric results from a narrow band survey of nearby star-forming regions for methane-bearing planetary mass objects have been published elsewhere<sup>6,7</sup>.

## 2. DESIGN REQUIREMENTS

Briefly, the desired properties of the instrument were as follows: a plate scale of  $\leq 0.5''$  per pixel to sample the best in-flight seeing at  $5 \mu\text{m}$ , an imaging format that captured the entire  $8'$  field of view of SOFIA, achromatic performance with no re-focus over the entire  $1\text{-}5.5 \mu\text{m}$  range, a throughput of  $>30\%$ , an accessible pupil image for a cold stop and a collimated beam for filters and grisms. To accommodate a spectroscopy mode, a cold focal plane aperture was needed together with a slit mask, and the collimated beam had to be large enough to ensure the required resolving power ( $R \sim 2,000$  for a 2 pixel slit). A pupil viewing mode was desired, but it was sufficient to optimize this mode for thermal IR imaging at L-band ( $3.5 \mu\text{m}$ ). Another constraint on the optical-mechanical design was imposed by the need to co-mount FLITECAM on the telescope with HIPO, a large CCD-based instrument for high speed occultation photometry and imaging at visible wavelengths. Table 1 summarizes the main instrument characteristics of FLITECAM.

Table 1: General characteristics of FLITECAM

Characteristic	Value
Wavelength range	1 to $5.5 \mu\text{m}$ ; L band for pupil viewing
Filters	J, H, K, L, M, plus narrow bands
Spectral resolution	1000 – 2000 in Grism mode
Spatial resolution	$0.46''$ per pixel
Detector type	InSb Raytheon ALADDIN III
Detector format	$1024 \times 1024$ pixels
Field of view on SOFIA	$\sim 8'$ diameter
Detector operational temperature	30 K
Cryostat type	20 L liquid nitrogen / 20 L liquid helium tanks
Read noise	$\sim 49$ electrons CDS (Fowler 1)
Well depth	$\sim 80,000$ electrons
Dark current	$\sim 1$ electron/sec
Instrument efficiency	$\sim 40\%$ (not including QE)
Detector quantum efficiency	$\sim 80\%$

## 3. DESCRIPTION OF THE INSTRUMENT

### 3.1 Optical design

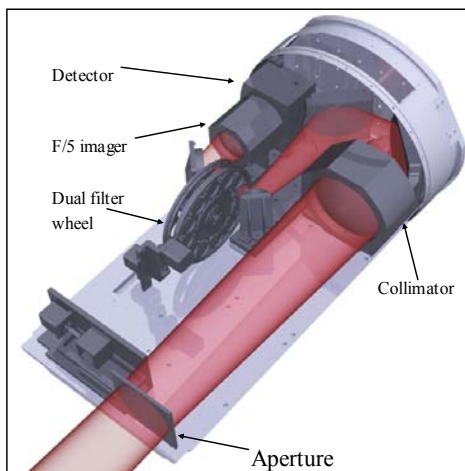

Figure 1: FLITECAM optical bench layout.

The initial optical design of FLITECAM is described by Horn and McLean<sup>8</sup> and optical performance of the as-built system is discussed by Mainzer<sup>5</sup>. FLITECAM's optical layout is shown in Figure 1 for normal imaging. Photons enter the vacuum-cryogenic chamber through an IR-transmitting window of  $\text{CaF}_2$  and come to a focus at the Aperture stop. The beam is collimated by a triplet of ZnS, BaF<sub>2</sub> and LiF and then folded into a compact geometry by four flat mirrors. A pupil image is formed at the entrance into a double filter wheel. After the fourth folding flat a camera lens group working at about  $f/4.7$  re-images the aperture onto the  $1024 \times 1024$  pixel array of the ALADDIN III InSb detector (Raytheon) which has 27-micron pixels. The camera has five elements consisting of BaF<sub>2</sub>, ZnSe, LiF, ZnS and ZnSe.

To convert FLITECAM to spectroscopic mode the aperture is replaced by an opaque metal mask with a long slit, and one of 3 grisms is selected in the second filter wheel<sup>9</sup>.

Each grism can be used in one of three orders by selection of the appropriate filter in the first filter wheel. The 2' long slit is made in two parts. One half has a width of 1" and the other half has a slit width of 2", thus providing two spectral resolution options with a single slit mask. Spectra are dispersed vertically across the full 1024 pixels of the array.

Finally, a pupil viewing mode can be achieved by inserting additional lenses into the collimated beam. This mode is optimized for L-band to enable FLITECAM to check the emissivity of the telescope primary mirror. To deploy the pupil viewing mode a lens in the second filter wheel is selected and a doublet is moved into the beam in front of the camera group. Figure 2 shows the optical layout of both imaging modes as a ray trace.

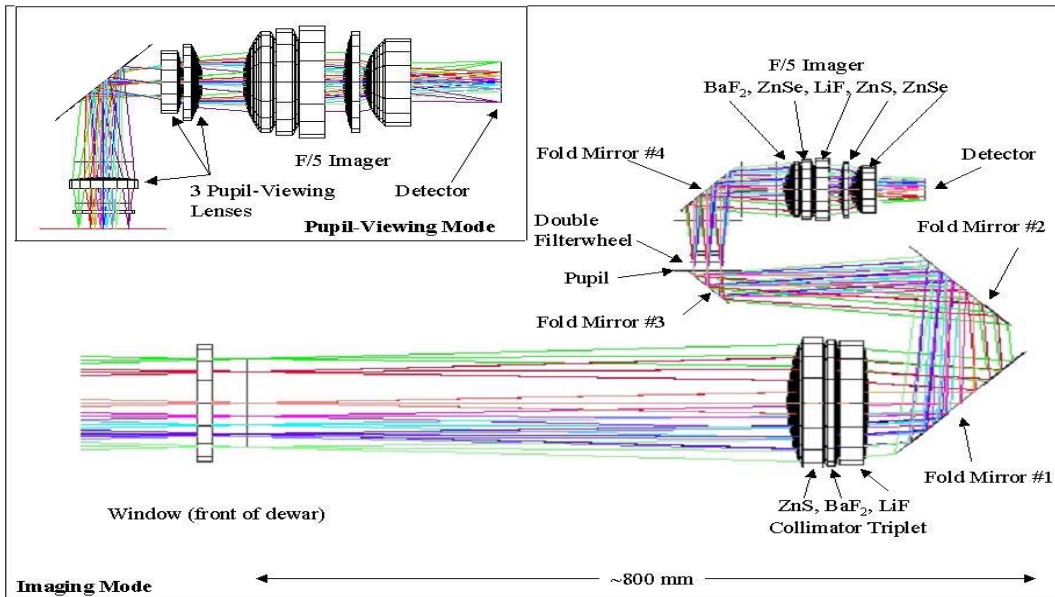

Figure 2: The FLITECAM optical layout, showing both imaging and pupil-viewing modes.

Originally, it was intended to use a 512 x 512 InSb array in FLITECAM. After the Preliminary Design Review the decision was made to upgrade to the 1024 x 1024 array to enable imaging of the entire 8' SOFIA field of view. This requirement drove the collimator lenses to ~165 mm in diameter. One of the most difficult aspects of FLITECAM's design is its large crystalline lenses. The fluoride lenses are known for fragility and susceptibility to thermal and mechanical shock. Each of the crystal lenses is carefully mounted in a holder with flexible fingers that allow differential motion between the lens material and the aluminum lens cell during cool down, without loss of centration. Figure 3 shows the assembled Collimator. The fold mirrors are mounted on a sub-plate and aligned first, then the Collimator and

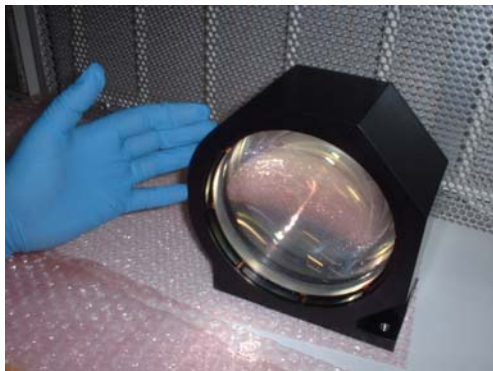

Figure 3: The assembled collimator.

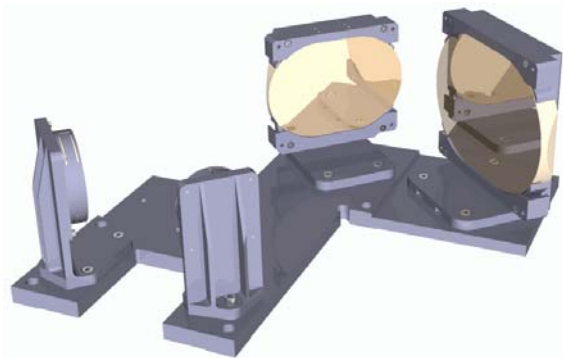

Figure 4: Fold mirrors and mini-optical sub-plate.

Camera lens groups are mounted against precision machined faces on the mirror sub-plate. The completed, enclosed and fully baffled optical bench is shown in Figure 5 during assembly in the clean room.

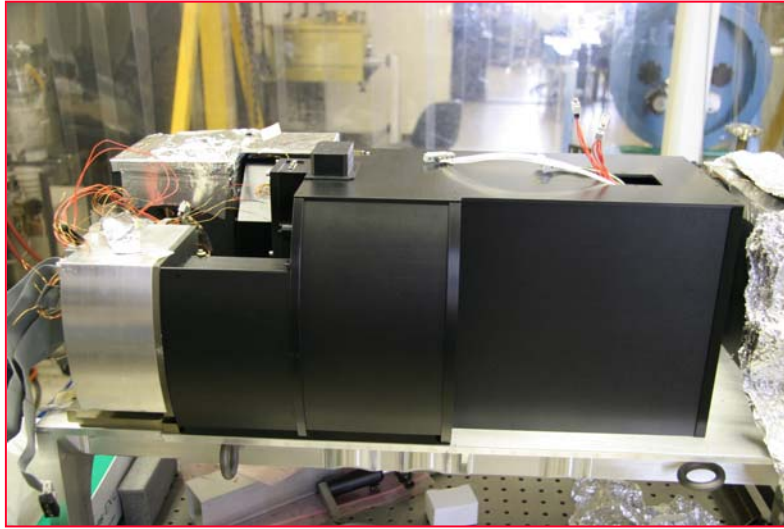

Figure 5: View from Camera side of fully enclosed optics. Detector module is on far left.

### 3.2 Mechanical design

Supporting the FLITECAM optical components is an optical bench of aluminum that is cooled with liquid nitrogen. A cylindrical LN<sub>2</sub>/LHe dewar fabricated by Precision Cryogenics of Indianapolis, IN was used to contain the optical bench and provide two equally sized reservoirs of 20 liters for each cryogenic liquid. Liquid helium is used only to provide a lower temperature bath in order to form a thermal bridge to the InSb detector which is stabilized and operated at 30 K using a Lakeshore 330 temperature controller and heating circuit.

A special design allows the FLITECAM cryostat to be operated in the horizontal position, as required for SOFIA, with maximum hold time, and in the vertical position, as needed for use at the Cassegrain focus of the Lick 3-m telescope. Typical hold times are 46 hours for LN<sub>2</sub> and 16 hours for LHe.

#### 3.2.1 Dewar Shell

The outer shell of the dewar is a cylinder 19 inches in diameter and 55½ inches long, with the entrance window in the front face, and the fill and vent tubes for the cryogen containers in the rear face, along with the vacuum pumping port and the vacuum gauge. This long outer cylinder is split just behind its middle with a large O-ring seal, with the cryogen containers housed in the rear portion, and the optical bench carrying the instrument components in the front. All internal components are attached to and supported from the rear portion, so access to the optical bench and everything mounted to it is achieved by removing the front section. Other than the window, there are no holes in the front section. Most electrical connectors are mounted into special flat connector plates on the wall of the rear section just behind the split. Vacuum and cryogenic fittings are in the rear face near the fill and vent tubes for the LN<sub>2</sub> and LHe cans. Two pop-off spring-loaded pressure relief valves are also mounted on the rear face. A welded platform on top of the rear section is used to mount the detector electronics crate. Handling fixtures are welded to the side of the dewar and there is also a protection ring attached to the rear plate. Figure 6 illustrates the construction and layout.

To gain access to the inside of the cryostat the front and rear parts of the dewar can be separated, or either end of the dewar can be removed. The entrance window is contained in a special sub-unit that can be removed without opening any other part of the dewar. Under normal operations the optical bench is vertical as shown in Figure 6.

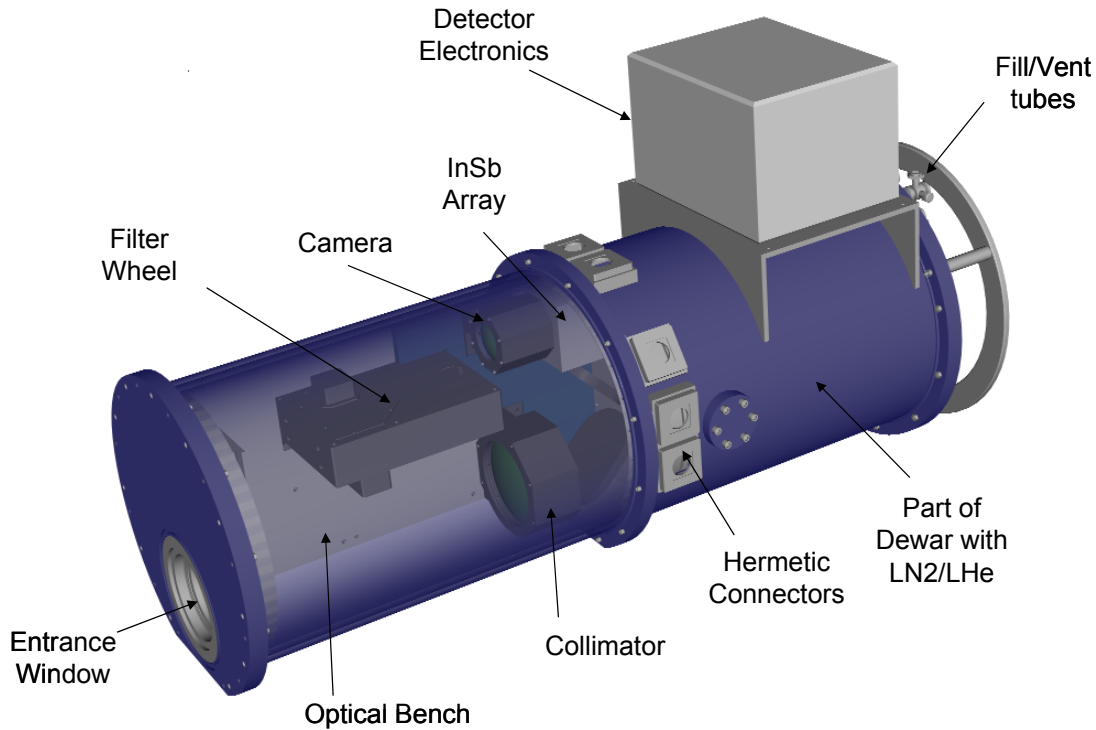

Figure 6: The FLITECAM LN2/LHe cryostat with a transparent layer view of a partially populated optical bench.

### 3.2.2 Support of internal structures

Support of the internal components and thermal isolation from the dewar walls is through three G10 tabs, best thought of as A-frames where the angle of the “A” has been opened up to 180 degrees. The tabs measure  $3\frac{3}{8}$  by  $1\frac{1}{8}$  by  $\frac{1}{8}$  thick, and are bolted through the middle to small blocks welded to the outer wall and at each end to the main support plate. The main support plate is a circular plate of  $17\frac{3}{4}$  inches diameter. This plate then supports the cryogen tanks to the rear and the optical bench to the front. The liquid nitrogen tank is attached to the rear face of the support plate by a matrix of bolts passing through the plate into tapped holes in the face of the tank. The helium tank is mechanically supported by, but thermally isolated from, the nitrogen tank by a thin cylinder of rolled G10 sheet.

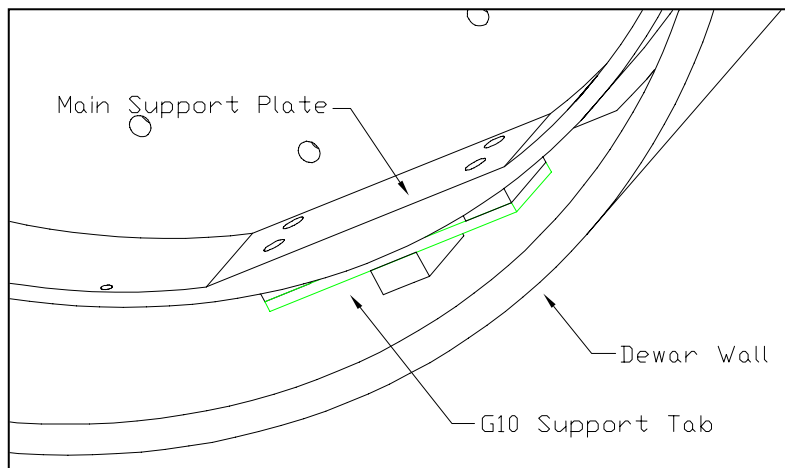

Figure 7: G10 A-frames used for thermal isolation.

The main support plate has a ridge running vertically to form a support ledge for the main optical bench. The optical bench is approximately 32 by 15 inches in extent, and  $2\frac{1}{2}$  inches thick. It is aggressively hollowed on the rear face to reduce weight, while retaining stiffness through ribs. Bolts passing through the support plate have their heads trapped in a rear slot, so that they form mounting studs for the optical bench. The bench is secured to the studs by hex bolts.

Because G10 is not a certified material for aircraft use, hard stops are built in that would prevent any significant motion of the bench or reservoirs should the G10 fail.



### 3.2.3 Instrument mounting and transport

Mounting of the instrument onto the SOFIA telescope is by means of a large (41 inch diameter) mounting plate and an approximately 9 inch long extender tube. This large plate is bolted to the telescope flange and it also has a smooth surface to mate with a large O-ring in the flange, inboard of the bolt circle around its edge. The extender tube and instrument front plate also have O-rings, because the Nasmyth tube of the telescope is open to the outside atmosphere at very low stratospheric pressure. In other words, the instrument must provide the pressure seal for the SOFIA cabin.



Figure 8: FLITECAM co-mounted with HIPO.

Optionally FLITECAM can be co-mounted to the SOFIA telescope with the HIPO instrument. In this case, the front plate of HIPO substitutes for FLITECAM's own mounting plate. A periscope arrangement including a dichroic beamsplitter, mounted behind the plate, feeds the infrared beam to FLITECAM, which mounts in an offset position as shown in Figure 8, thus dispensing with the extender tube. In the picture, both HIPO and FLITECAM are attached to the 72 inch Perkins telescope at Lowell Observatory.

The rear section of the dewar shell has two welded bosses to which are attached trunnions which interface the instrument to its handling cart. The cart incorporates a hydraulically actuated lifting structure to enable the instrument to be lowered for transportation and raised to the appropriate height for mounting to the telescope, and a screw jack for fine control of instrument tilt during mounting. The lifting arrangement has to lower the instrument far enough that the top is less than 60 inches from the floor for safe handling, and raise it high enough not only to reach its standalone mounting position but to reach over HIPO for co-mounting.

The SOFIA handling cart also contains a dead-man brake which prevents any possibility of a run-away in the cart encounters a slope.

### 3.2.4 Cryogenic setup

Both cryogen tanks in FLITECAM are welded aluminum cylinders. The liquid nitrogen tank of 25 liter capacity bolts directly to the main support plate, which is suspended from the dewar outer wall by isolating G10 tabs. A support structure formed by a rolled cylinder of thin (.060in) G10 sheet, epoxied into two slim aluminum collars, is used to support the liquid helium container from the rear of the nitrogen container. The helium container holds 22 liters of liquid. A cold shield bolted to the nitrogen container surrounds the helium container and its support structure. To allow passage of the copper cold finger from the helium container, the nitrogen container has a one inch diameter tube passing through it, connecting front and back faces. Each container has two ½ inch diameter fill/vent tubes. The diameter of the helium container is less than that of the nitrogen container, so the nitrogen fill tubes can pass by the helium tank to the rear wall of the dewar. All four tubes include bellows to accommodate the thermal contraction of the tanks and the tubes during cool down, and to increase the thermal conduction path from the dewar wall to the tanks. Each tube terminates in a welded steel "top-hat" structure which projects out through the dewar wall and is secured by a nut on the outside. The outer end of each tube has a KF10 flange for easy attachment of fittings.

The left tube into each tank is the fill side, and ends in a conical receiver which mates with the supply tube tip. Liquid introduced through the supply tube into the receiver then passes to the bottom of the tank through a ⅛ inch capillary tube. The capillary tube ensures a smooth delivery of liquid to the bottom of the tank, but also permits the liquid to be removed from the tank. Introducing a simple tube into the receiver and then pressurizing the tank with dry gas drives liquid up the capillary and out of the tube. This is mostly used to remove pre-cool nitrogen from the helium tank, but is also useful if the instrument needs to be warmed up and there is a significant charge of cryogen in either tank. The walls of each fill-side tube are perforated so that boil-off gas can pass out via the tube when no supply/siphon tube is inserted

into the receiver. Both of these cans have been pressure tested under FAA supervision to 3 times the highest pressure likely to occur if the cryogenics were to boil off rapidly and vent only through the pair of half-inch diameter tubes.

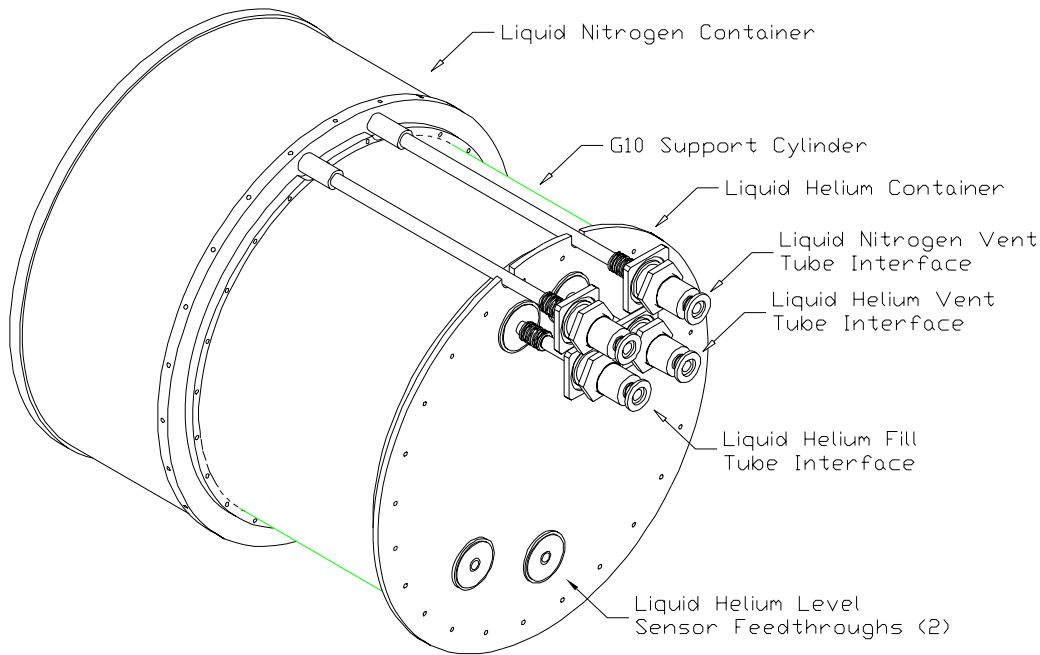

Figure 9: LN2/LHe reservoirs and fill/vent tube arrangement.

Because FLITECAM was designed to be used on ground-based telescopes as well as on SOFIA, provision was made for operation in up-looking as well as horizontal operation. Each fill or vent tube is near the top of the tank in horizontal position, and goes almost to the far (front of dewar) wall of its tank, so the tanks can be mostly full when the instrument is in either horizontal or vertical orientation. In addition, the fill capillaries already mentioned curve towards the rear of the instrument so that their tips are at the bottom of the liquid in either orientation.

The helium container has been instrumented with a pair of helium level sensors allowing a direct readout of liquid helium level. The sensors consist of a perforated G10 tube containing a wire which changes to a superconductor when immersed in liquid helium. Since the sensor is welded inside the tank, we had two installed for redundancy. The sensor tubes are oriented with the high end at the top front of the tank and the low end at the bottom rear of the tank. This means the tubes are at 45 degrees to the liquid surface in either horizontal or vertical orientation, so the readout works for both applications. Finally, there are two getters in the system. One contains activated charcoal and is attached to the primary support plate at 77 K, and the other contains Zeolite and it is attached to the copper cold finger to the liquid helium container.

### 3.2.5 Shielding

An aluminum cold shield surrounds the liquid helium vessel and is connected to the liquid nitrogen can, to ensure that the LHe is completely enclosed in a 77 K environment. The outer surface of the nitrogen container and the shield around the helium container are wrapped in multiple layers (~10) of aluminized Mylar to provide additional radiation shielding.

The optical bench has another circular plate bolted to it at the front end of the instrument, matching in diameter with the main circular support plate in the rear. A cylindrical aluminum cold shield slides over the front circular plate and fastens to the rear plate to envelop the optical components. The forward lip of the main support plate mates to an aluminum ring

approximately 3 inches wide carrying all the electrical feedthroughs into the optical enclosure, and the rear edge of the cold shield mates with this ring. After the cold shield is secured to the ring the joint is taped up with opaque aluminum tape. The outer surface of this cold shield is also wrapped with about ten layers of aluminized Mylar.

### 3.2.6 Cooling of detector head

Cooling of the detector head is via a copper cold finger in the form of a ½ inch diameter solid copper rod from the helium container. Inside the LHe container this rod curves downward to the bottom rear of the container, so that like the fill capillaries its tip is in the liquid at the bottom of the tank in either horizontal or vertical orientation. The outer portion of the rod passes through the tube in the LN2 can, and a matching hole in the main support plate. A short rod of the same diameter is clamped to its tip at right angles to bring the cooling source to a convenient place in the dewar for attachment of the getter, a temperature sensor and a thin copper foil strap which connects to the detector head.

The detector head has an outer light-tight aluminum shell, with the detector enclosure mounted inside on G10 isolating tabs. The inner assembly is cooled to ~30K by the cold strap, which connects through the outer shell via an isolated copper plug incorporating a thin (~.001 inch) mica washer which provides a thermal path while maintaining electrical isolation. The detector head (and electronics) were provided by Doug Toomey of Mauna Kea Infrared Systems.

### 3.3 Electronics design

FLITECAM uses an array controller purchased from Mauna Kea Infrared (MKIR) Systems of Hilo, HI. The MKIR electronics digitize the signals from the InSb detector, supplies the voltages and currents necessary to run the array, and communicates with the main FLITECAM computer system. The MKIR electronics has Digital Signal Processors (DSPs) that coadd individual frames to reduce disk storage space. Part of the MKIR electronics is contained in a package that mounts directly to the cryostat. Fiber optic cables connect the instrument pack to the MKIR computer. In turn, this computer connects to the main FLITECAM computer via serial interface. A Pulizzi power controller handles all of FLITECAM's electronics, including the dewar electronics, filter wheel motors, Lakeshore 218 and 330 temperature monitors, helium level sensor, and vacuum gauge. FLITECAM's electronics and computers are therefore distributed between two racks. The Counter Weight (CW) rack that is mounted on the telescope and the Principal Investigator (PI) rack that is located well away from the telescope in the control room or operations area. These racks are illustrated in Figure 10.



Figure 10: CW rack (left) and PI rack (right). The former contains instrument electronics and PI rack holds computers.



### 3.4 Software design

The software infrastructure for the SOFIA project has been developed using a design paradigm that is more object oriented and largely based on Common Object Request Broker Architecture (CORBA). CORBA is an interface definition language that allows objects written in different languages, running on diverse operating systems, and on different networks to interact as if they were running within a single program. The FLITECAM Instrument Control Software System (FICSS) is not a single massive program but a set of independent programs that act together to control all aspects of the instrument's operations. Programs within the FICSS function as containers for a set of distributed CORBA objects, created by different programs, and running on several computers within a network. The highly distributed nature of the FICSS enhances the stability and reliability to a great extent. FICSS was written entirely in the Java programming language using the JBuilder integrated development environment. The current system is deployed using JRE 1.4.1 on two Windows 2000 Server computers. The software is deployed using InstallAnywhere to create native executables that bundle the correct Java virtual machine with all the configuration and command line parameters required to run the programs properly. One of the computers provides all background services (e.g. database, IDL-ION, CORBA-ORB, etc.) and supports those programs that continuously monitor the state of the hardware, while a separate computer is used strictly for running the instrument control software and the astronomer's interface to the system. A separate VME bus Solaris single board computer is used to control the detector electronics provided by MKIR. Communications between the programs within the FICSS are done using the Visibroker Object Request Broker (CORBA). Communications between the FICSS and external (e.g. Shane telescope control system, SOFIA Mission Control System (MCS)) and legacy systems (i.e. MKIR) are handled by multiple TCP/IP sockets.

Each of the subsystems within the FICSS can be configured to operate in "simulation" mode where the value of every parameter is simulated rather than derived from communication with an actual instrument. In addition, each of the external systems that the instrument communicates with has also had a simulator designed to replace it during development. Building simulators, although time-consuming, has substantially aided in our ability to refine the operation of the software and to continue development even when the hardware was unavailable.

Programs within the FICSS are built around highly customized graphical interfaces that operate by events propagated by the user using the GUI. The system can also be operated by remotely invoking methods on CORBA objects. In other instrument control systems the common way to carry out a complex sequence of astronomical observations is to construct a "script" that sequentially executes. The FICSS operates on a more "atomic" level however where a complex set of observations is specified in an Astronomical Observation Request (AOR). Unlike a sequential script, an AOR describes a set of observations to be performed and the software is sophisticated enough to configure the instrument to carry them out. For example, a user specifies that a spectroscopy experiment within a particular wavelength range is to be conducted using a set of 3 ABBA nods along the slit. When the AOR is executed the software moves the entrance slit into the optical beam, moves in the correct grism and blocking filter, and then starts a sequence of 12 exposures with telescope moves to nod along the slit interspersed throughout. An AOR can describe a single exposure or a complex 27-point dither pattern including all of the instructions necessary to automatically reduce the data. AOR's are stored as XML documents using a Document Type Definition (DTD) developed by the SOFIA Data Cycle System. The FLITECAM software contains an internal editor that can be used to construct and edit AOR's to carry out imaging operations (i.e. dithering) or spectroscopy. AOR documents may also be created by other programs and submitted for execution (e.g. MCS observation queue) by invoking methods on a remote control CORBA object. In a similar fashion, an astronomer might use a dedicated external AOR editor to construct an entire nights worth of observations that are delivered to the FICSS on disk and executed once the instrument is on the sky.

The three major programs within the FICSS are the Astronomer's Interface (AI), shown in Figure 11, the PTServer and the Mechanism Server. The PTServer is responsible for monitoring all of the housekeeping components including a temperature monitor, temperature controller, helium level monitor, vacuum gauge and a power controller. All housekeeping data collected during operation is stored in an INFORMIX database management system and the entire thermal history of the instrument can be retrieved at will. The Mechanism Server is the program responsible for supporting the operation of the four cryogenic mechanisms: two filter-wheels; a slit-aperture mechanism and a pupil lens slide mechanism.

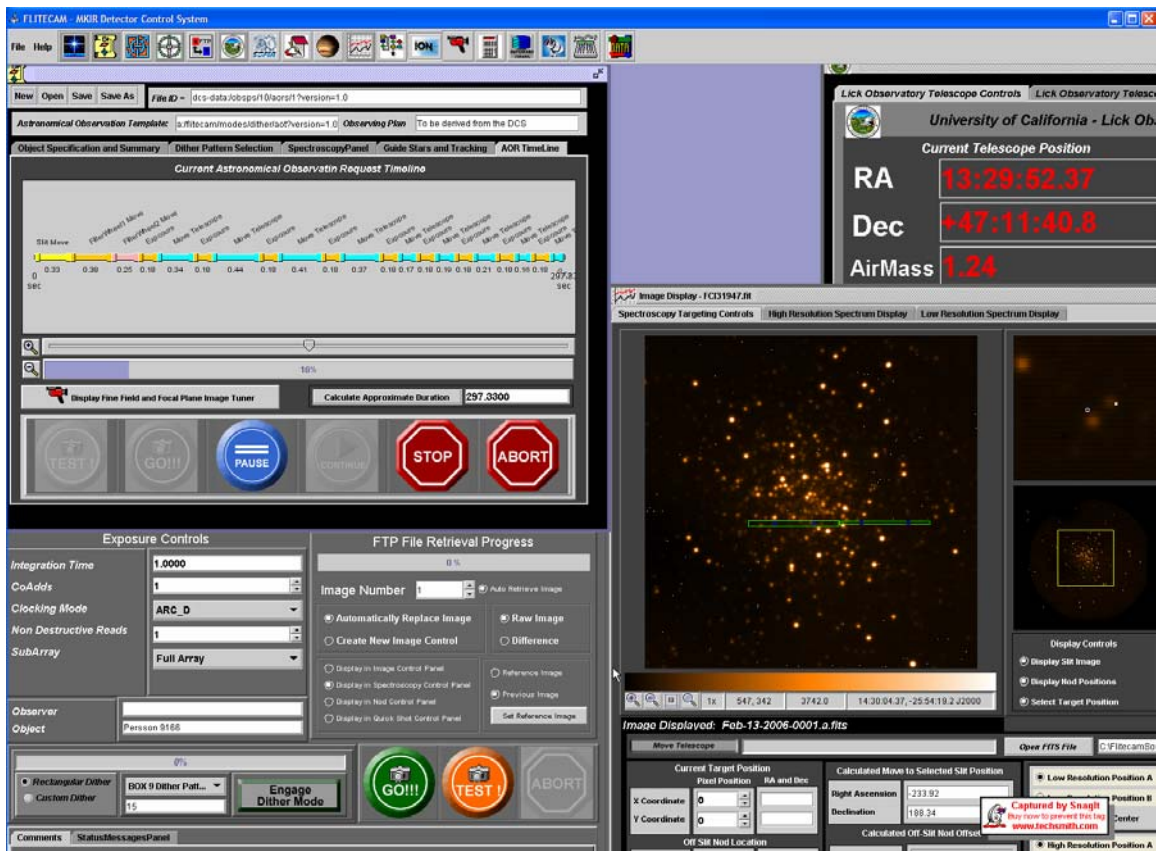

Figure 11: The “Astronomer’s Interface” showing some of the available controls including the AOR tool (upper left).

It is the AI that is the primary client for the services provided by other programs in the system. This program is used to carry out all observations, either by execution of AOR’s or by using manual controls. When an exposure is carried out the AI program uses the MKIR software to construct a primitive FITS file containing the data. The FITS image file is then retrieved and the header is updated with housekeeping data derived from the PTServer and the mechanism configuration obtained from the Mechanism Server. The AI program is also responsible for monitoring the status of the telescope and for executing any telescope motion commands required for an observation. Typically, the AI program is started at the beginning of the night and then closed once all observations are completed. All of the other programs in the system are designed to run continuously as long as power is available to the instrument.

A data reduction pipeline (DRP) is available for reducing imaging observations (e.g. dither patterns) automatically. The AI program uses a TCP/IP socket to connect to an ION Server (an RSI product) installed on one of the computers in the local area network to execute the IDL code. ION is a Java program interface to IDL that allows IDL programs to be run from within a Java program. The DRP is designed to be a simple, robust tool that produces a reconstructed image of the object and sky corrected for gain variations and anomalous pixels but without flux calibration, i.e. the final result is in counts/second/pixel. In addition, the DRP can be executed automatically as part of the SOFIA Data Cycle System. The DRP takes the resulting raw frames of a FLITECAM dither observation (e.g. Box-9 or 27-point) and combines them to form a single, reduced image. No external files are required for basic dither reductions, although an optional flat field can be specified. Output is a final, reduced image in counts/pixel/second stored in FITS format with all processing steps recorded as HISTORY fields in the header. Optional outputs include the individual reduced dither frames before stacking into the final image and the intrinsically derived flat field (all stored as FITS files).

FLITECAM benefited greatly from a large number of open source code repositories including the JSky archive. Program design was heavily influenced by the opportunity to examine and study the source code for the Science Expert Assistant (SEA) project and the Science Proposal and Observing Tool (SPOT) developed for SIRTf/Spitzer. JFreeChart, Diva and the Java Advanced Imaging (JAI) open source projects have also represented significant contributions to the FICSS. JFreeChart is used extensively for the display of graphs such as temperature vs. time charts. Diva and JAI are used together to display FITS images and graphical overlays derived from code in the JSky archive.

#### 4. OBSERVATIONAL RESULTS

As a result of the “upgrade” of FLITECAM at CDR, the decision was made to accept an engineering grade 1024 x 1024 InSb array instead of the planned 512 x 512 device but at the same cost. This 1024 ALADDIN III chip has relatively poor response in the corners of the array and there is a large region (~15% of area) of lower quantum efficiency in one quadrant of the detector; the relative change in QE is almost a factor of two at the worst point. The effect of this low QE region appears worst at the shortest wavelengths (e.g. J-band) where the estimated QE~60%, compared to about ~80% at longer wavelengths. Read noise for this detector is nominal at about 43e- rms (6 DN) in a single correlated double sample (CDS). The minimum CDS readout time is 0.33 s for a full frame. Multiple (Fowler) Sampling is effective in reducing noise; 9 or 16 reads is a typical setting. Dark current plus residual photon background within the dewar is ~5 e/s/pixel on average. Most of this signal is probably photon leakage because there is very little change in this signal when the reverse bias on the detector is cycled from 0-500 mV or for temperatures in the 30-35 K range. This detector has a high percentage of hot pixels with dark current >10x average, even when operated at 30 K. Charge persistence is typical of InSb devices. Over-exposure must be followed by multiple reads to reduce the after image to <0.1% of the original signal.

Optical performance on-axis is good. Image diameters of ~2 pixels (0.86”) were observed at Lick Observatory under the best conditions. This image quality extends over the central 3’ diameter of the 7.6’ diameter field (at Lick). Beyond the central region there is an increase in coma or flare. Recent re-analysis of the optical design shows that this flare is inherent to a particular optical group in the 5-element camera lens and could be minimized by a new design. Under poorer seeing conditions experienced at Lick (~2” FWHM) the effect of the flare is only noticeable around the outer 1’ annulus. Optical transmission is high and essentially as predicted. Throughput values are typically about 40-45%. This number includes the window, collimator, fold mirrors, filter and camera. With a typical QE of 80%, the implied instrument-only throughput is about 32%.

Zero-points (i.e. the magnitude corresponding to 1 DN/s/pixel in the instrument) for J, H, K and L (deduced from a narrow band measurement) were obtained at Lick Observatory. The best measured values were J =21.66, H= 21.25, K = 20.08 and L = 16.01. Sensitivity at K and L is limited by telescope thermal background and the low-altitude site. The instrument is background-limited for all broad-band and narrow-band measurements obtained so far.

Using this information one can estimate the sensitivity of FLITECAM on SOFIA assuming a cold telescope (250 K) but the same OH background at J and H as observed on the ground. Assuming 5” FWHM images, a S/N ratio of 4 can be obtained in 900 s on the 2.5-m SOFIA telescope with 15% assumed emissivity for the following limiting magnitudes: J = 20.1, H = 19.3, K = 19.2, L = 15.6, M = 13.4. The L and M values are rough estimates. No M-band measurements have been made with FLITECAM; even with a narrow band, the Lick backgrounds are too high and sub-array mode is required. All L-band data have been obtained using a 256 x 256 sub-array. The 1 sigma, 1 hour noise equivalent flux densities on SOFIA would then be: J ~2 μJy, H ~3 μJy, K ~2 μJy, L ~20 μJy, and M ~100 μJy

Figure 12 illustrates results from different runs at Lick Observatory. In the center is a picture of the Orion Nebula reduced by the pipeline and then combined into a 3-color composite. The image of the Orion Bar in the bottom left panel of Figure 12 was obtained using a narrow band filter centered on the 3.3 μm PAH feature and a 512 x 512 sub-array to improve read out time. Apart from the JHK color composite, the results are as-seen at the telescope.

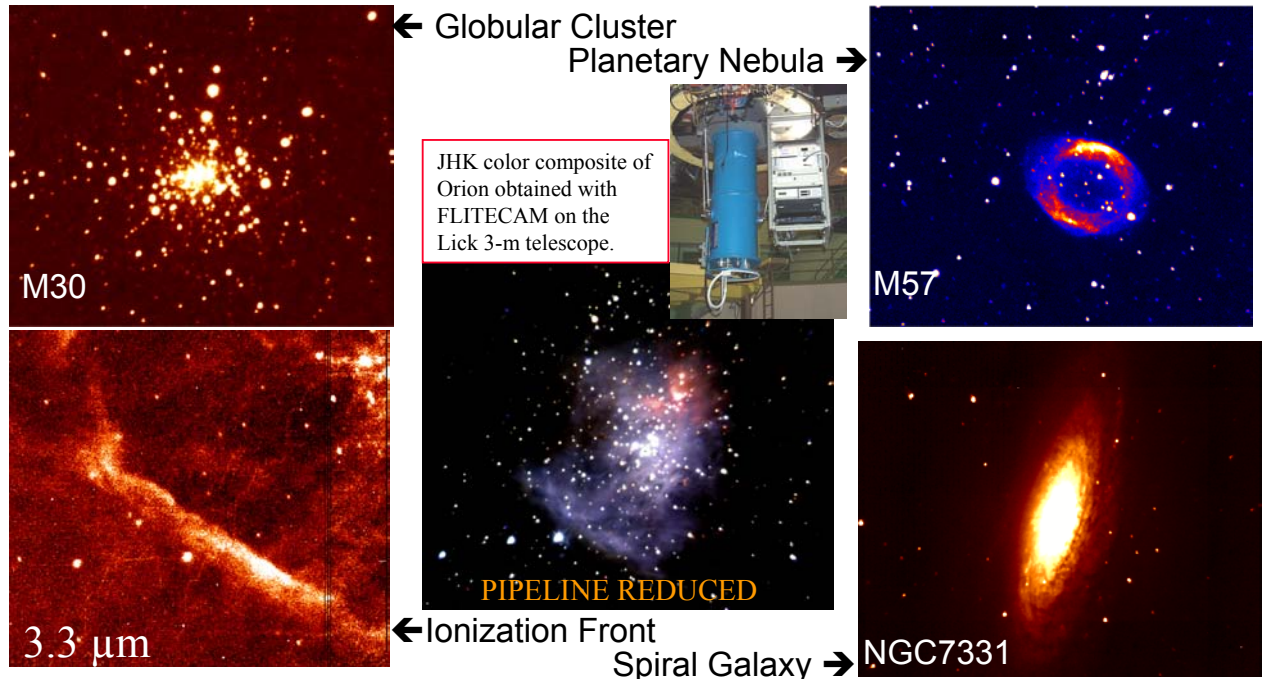

Figure 12: A selection of imaging results obtained with FLITECAM on the 3-m telescope at Lick Observatory.

#### ACKNOWLEDGEMENTS

It is a pleasure to acknowledge the many people that have worked on the development of FLITECAM from its inception to the present time. In particular we thank Don Figer, Jochen Horn and Amy Mainzer for their original contributions. We also thank the team at USRA as well as former members of the UCLA IR Lab staff including John Goulter, Nick Magnone, Mike Spencer and Gunnar Skulason. Development of FLITECAM was funded partially by grants from USRA and partially from UCO/UCLA funds. Special thanks are due to the Lick Observatory staff for their outstanding support on our many visits to Mt. Hamilton.

#### REFERENCES

1. E. F. Erickson, "SOFIA: The next generation airborne observatory," *Space Sci. Reviews* **74**, 91-100, 1995.
2. E. W. Dunham and B. Taylor, "HOPI: high-speed occultation photometer and imager for SOFIA," in *Airborne Astronomical Systems*, Proc. SPIE **4014**, 2000.
3. D. F. Figer, I. S. McLean, and E. E. Becklin, "FLITECAM: a 1-5  $\mu\text{m}$  camera for testing the performance of SOFIA," in *Infrared Astronomical Instrumentation*, A. Fowler, ed., Proc. SPIE **3354**, 1179-1184, 1998.
4. J. M. M. Horn, E. E. Becklin, O. Bendiksen, G. Brims, J. Goulter, E. Kress, N. Magnone, I. S. McLean, J. Milburn, N. Molayem, H. S. Moseley and M. Spencer, "FLITECAM – A near infrared camera for test and science applications on SOFIA," in *Airborne Telescope Systems*, Ramsey K. Melugin, Hans-Peter Röser, Editors, Proc. SPIE **4014**, 65-76, 2000.
5. A. K. Mainzer, I. S. McLean, T. Aliado, E. E. Becklin, G. Brims, J. Goulter, E. Kress, N. Magnone, J. Milburn, G. Skulason, M. Spencer, "Characterization of FLITECAM: the first light camera for SOFIA," in *Airborne Telescope Systems II*, Ramsey K. Melugin, Hans-Peter Röser, Editors, Proc. SPIE **4857**, 21-28, 2003.
6. A. K. Mainzer and I. S. McLean, "Using narrow band photometry to detect young brown dwarfs in IC348," *Astrophysical Journal*, **597**, 555-565, 2003.
7. A. K. Mainzer, I. S. McLean, J. L. Sievers and E. T. Young, "Using narrow band photometry to classify stars and brown dwarfs," *Astrophysical Journal*, **604**, 832-841, 2004.
8. J. M. M. Horn and I. S. McLean, "Optical design of FLITECAM," in *Optical and IR Telescope Instrumentation and Detectors*, Masanori Iye, Alan F. M. Moorwood, Editors, Proc. SPIE **4008**, 979-989, 2000.
9. E. C. Smith and I. S. McLean, "Grism spectroscopy with FLITECAM," these proceedings.